

3 - 3L SERIES

CENTRIFUGAL ELECTRIC PUMPS STANDARDISED IN COMPLIANCE WITH EN 733 (EX DIN 24255)

Standardised centrifugal electric pumps built in stainless steel AISI 304 (3 SERIES) and AISI 316 (3L SERIES).



APPLICATIONS

- Water supply to civil, agricultural and industrial plants
- Pressure boosting
- Fire-fighting, heating and air conditioning systems
- Pumping industrial liquids
- Irrigation
- Refrigeration towers
- Swimming pools
- Emptying
- Washing plants

TECHNICAL DETAILS

- Highly resistant structure
- Hydroforming process EBARA patent

PUMP TECHNICAL DATA

- Maximum working pressure: 10 bar
- Temperature of the liquid:
 - 10°C ÷ +90°C
 - 10°C ÷ +110°C (L-H-HS-HW-HSW versions)
 - 20°C ÷ +120°C (E-ES versions)
- MEI > 0.4

For further information please see our Data Book on the web site www.ebara-europe.com

MOTOR TECHNICAL DATA

- IE3 high energy-efficiency motors starting from 0.75kW
- Self-ventilated 2 and 4 poles asynchronous motor
- Class of insulation F (B for high temperatures)
- IP 55 protection degree
- 230V ±10% 50Hz single phase voltage, 230/400V ±10% (up 4 kW included) three phase voltage, 50 Hz, 400/690V ±10% (from 5.5 kW and above) three phase voltage, 50 Hz
- Protection is user's responsibility

MATERIALS

- Pump casing and casing cover in:
 - AISI 304 for 3 SERIES 32-125/160/200
40-125/160/200
50-125/160/200
65-125/160/200
 - AISI 316L for 3L SERIES 32-125/160/200
40-125/160/200
50-125/160/200
65-125/160/200
 - AISI 316 microcasted for 3L SERIES 65-250
80-160/200/250
- Impeller in:
 - AISI 304 for 3 SERIES 32-125/160/200
40-125/160/200
50-125/160/200
 - AISI 316L for 3L SERIES 32-125/160/200
40-125/160/200
50-125/160/200
 - AISI 316 microcasted for 3 SERIES 65-125/160/200
3L SERIES 65-125/160/200
65-250
80-160/200/250

Available in 4 versions with 2 and 4 pole motors

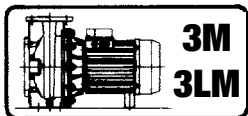

Monobloc with extended motor shaft

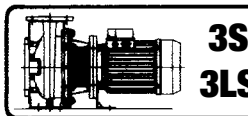

Monobloc with standard motor and rigid joint

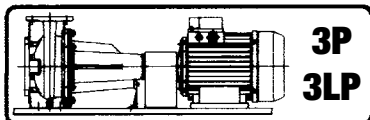

On base, with standard motor and flexible coupling

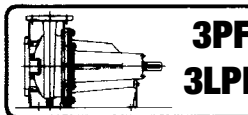

Pump with bare shaft

SPECIAL VERSIONS

- 3Z SERIES: electropump inclusive of rotary bracket and body without supporting foot.

ACCESSORIES (On request)

- Counter-flanges available in the following materials:
 - galvanised
 - AISI 304
 - AISI 316

- Mechanical seal standard in:
 - Carbon/Ceramic/NBR for 3 SERIES
 - Silicon Carbide/Silicon Carbide/FKM for 3L SERIES
 - special mechanical seals available on request, see p. 92 for 3-3L SERIES 2 poles, p.130 for 3-3L SERIES 4 poles

3 - 3L SERIES

CENTRIFUGAL ELECTRIC PUMPS STANDARDISED IN COMPLIANCE WITH EN 733 (EX DIN 24255)

IDENTIFICATION CODE - 2 Poles

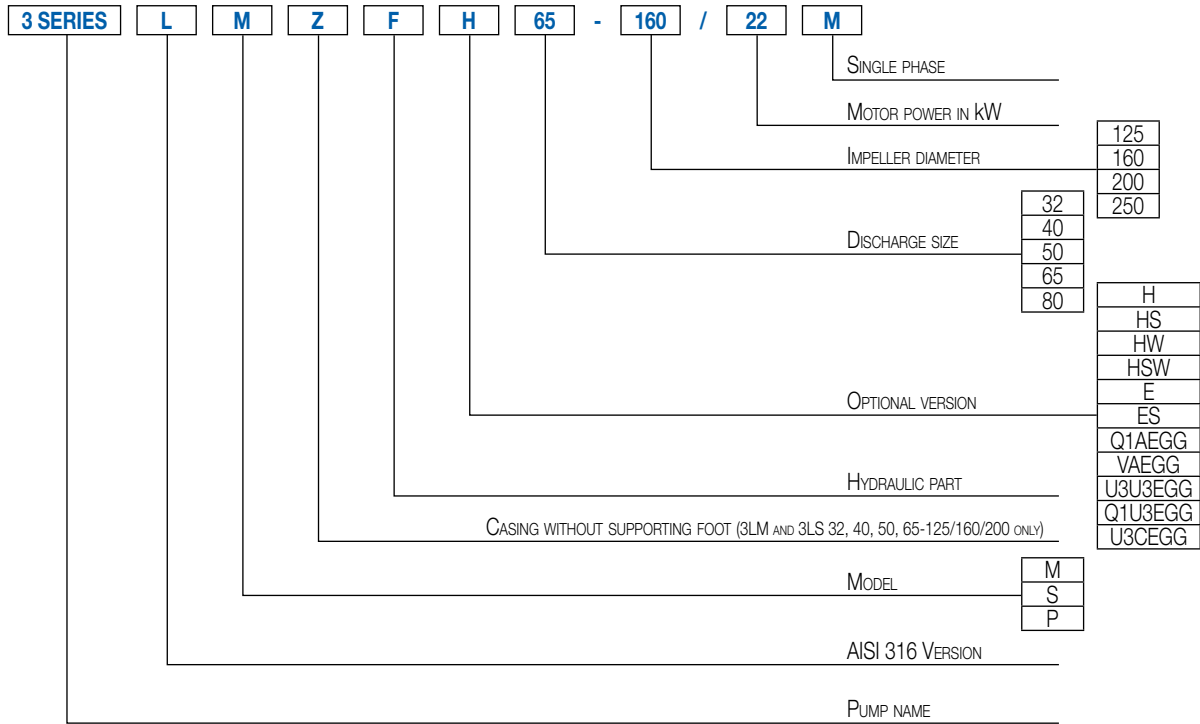

IDENTIFICATION CODE - 4 Poles

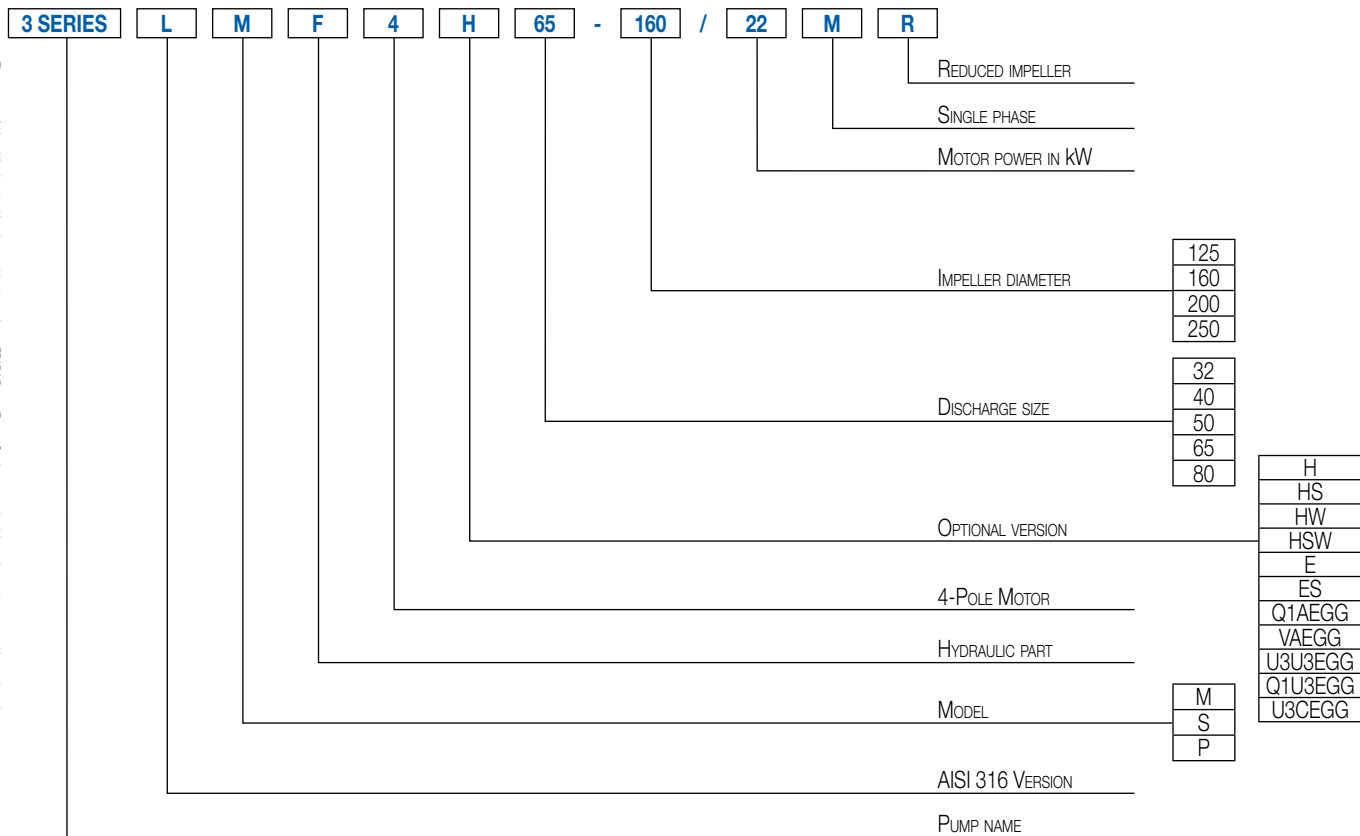

The content of this publication should not be considered mandatory. EBARA Pumps Europe S.p.A. reserves the right to change the content without prior notice.

3 - 3L SERIES

CENTRIFUGAL ELECTRIC PUMPS STANDARDISED IN COMPLIANCE WITH EN 733 (EX DIN 24255)

PERFORMANCE RANGE 3(L) SERIES at 2900 min⁻¹ (according to ISO 9906 Attachment A)

2 Poles

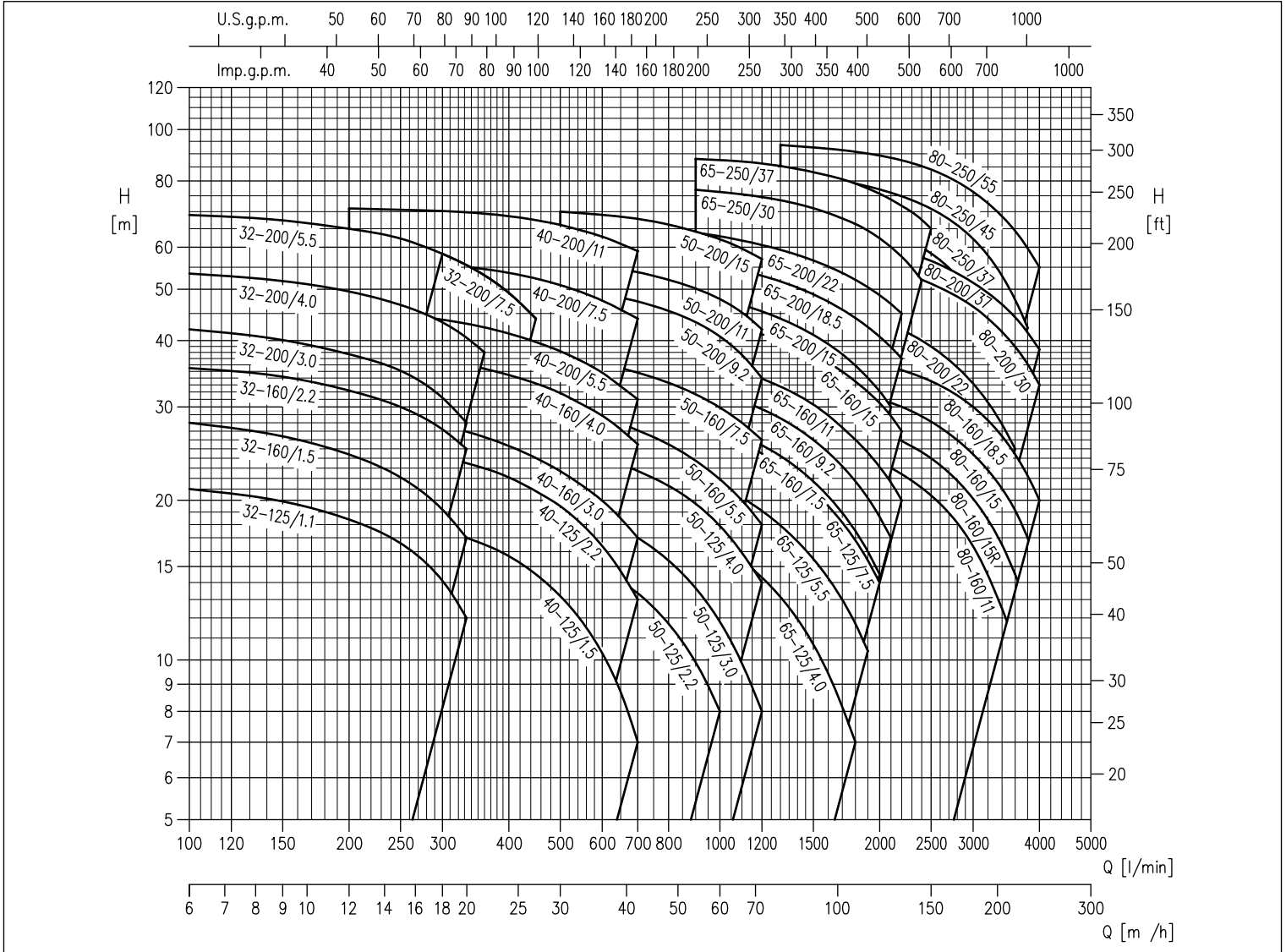

Versions	3M	3S	3P	3LM	3LMZ	3LS	3LSZ	3LP
32-125	■	■	■	■	◆	■	◆	■
32-160	■	■	■	■	◆	■	◆	■
32-200	■	■	■	■	◆	■	◆	■
40-125	■	■	■	■	◆	■	◆	■
40-160	■	■	■	■	◆	■	◆	■
40-200	■	■	■	■	◆	■	◆	■
50-125	■	■	■	■	◆	■	◆	■
50-160	■	■	■	■	◆	■	◆	■
50-200	■	■	■	■	◆	■	◆	■
65-125	■	■	■	■	◆	■	◆	■
65-160	■	■	■	■	◆	■	◆	■
65-200	■	■	■	■	◆	■	◆	■
65-250	-	-	-	-	-	●	-	●
80-160	-	-	-	●	-	●	-	●
80-200	-	-	-	-	-	●	-	●
80-250	-	-	-	-	-	▲	-	▲

- = Models also available in H-HS-HW-HSW-E version
- = Models also available in H-HW-HSW-E version
- ▲ = Models also available in H-HW-HSW-ES version
- ◆ = Models available only in standard version

The content of this publication should not be considered mandatory. EBARA Pumps Europe S.p.A. reserves the right to change the content without prior notice.

3 - 3L SERIES

CENTRIFUGAL ELECTRIC PUMPS STANDARDISED IN COMPLIANCE WITH EN 733 (EX DIN 24255)

PERFORMANCE CHART 32-40-50

2 Poles

Model	P ₂		Q = Flow Rate														
	[HP]	[kW]	l/min m ³ /h	100	150	200	300	333	360	400	450	500	600	700	800	1000	1200
				6	9	12	18	20	22	24	27	30	36	42	48	60	72
H=Head [m]																	
3(.) SERIES 32-125/1.1(M)	1.5	1.1	21.0	19.9	18.4	14.1	12.0	-	-	-	-	-	-	-	-	-	-
3(.) SERIES 32-160/1.5(M)	2	1.5	28.0	26.5	24.5	19.2	17.0	-	-	-	-	-	-	-	-	-	-
3(.) SERIES 32-160/2.2(M)	3	2.2	35.5	34.0	32.0	27.0	25.0	-	-	-	-	-	-	-	-	-	-
3(.) SERIES 32-200/3.0	4	3	42.0	40.0	37.5	31.0	28.0	-	-	-	-	-	-	-	-	-	-
3(.) SERIES 32-200/4.0	5.5	4	53.5	52.0	49.5	43.5	40.5	38.0	-	-	-	-	-	-	-	-	-
3(.) SERIES 32-200/5.5	7.5	5.5	69.0	67.5	65.0	58.5	-	-	-	-	-	-	-	-	-	-	-
3(.) SERIES 32-200/7.5	10	7.5	69.0	67.5	65.0	58.5	55.5	53.0	49.0	44.0	-	-	-	-	-	-	-
3(.) SERIES 40-125/1.5(M)	2	1.5	-	-	19.0	17.6	17.0	16.5	15.7	14.5	13.2	10.3	7.0	-	-	-	-
3(.) SERIES 40-125/2.2(M)	3	2.2	-	-	25.5	24.0	23.5	23.0	22.0	21.0	19.5	16.4	13.0	-	-	-	-
3(.) SERIES 40-160/3.0	4	3	-	-	29.5	27.5	27.0	26.5	25.5	24.0	22.5	20.0	17.0	-	-	-	-
3(.) SERIES 40-160/4.0	5.5	4	-	-	38.5	37.0	36.0	35.5	34.5	33.0	32.0	29.0	25.5	-	-	-	-
3(.) SERIES 40-200/5.5	7.5	5.5	-	-	45.5	44.0	43.0	42.5	41.0	39.5	38.0	35.0	31.0	-	-	-	-
3(.) SERIES 40-200/7.5	10	7.5	-	-	57.0	55.5	55.0	54.5	53.5	52.5	51.0	47.5	44.0	-	-	-	-
3(.) SERIES 40-200/11	15	11	-	-	71.0	70.0	70.0	69.5	68.5	67.5	66.0	63.0	59.0	-	-	-	-
3(.) SERIES 50-125/2.2(M)	3	2.2	-	-	-	-	-	-	17.5	17.0	16.3	14.9	13.4	11.7	8.0	-	-
3(.) SERIES 50-125/3.0	4	3	-	-	-	-	-	-	20.5	20.0	19.6	18.4	17.0	15.4	11.8	8.0	-
3(.) SERIES 50-125/4.0	5.5	4	-	-	-	-	-	-	26.0	25.5	25.0	24.0	22.5	21.5	17.9	14.0	-
3(.) SERIES 50-160/5.5	7.5	5.5	-	-	-	-	-	-	31.0	30.5	30.0	28.5	27.0	25.5	22.0	18.0	-
3(.) SERIES 50-160/7.5	10	7.5	-	-	-	-	-	-	38.5	38.0	37.5	36.0	35.0	33.5	30.0	26.0	-
3(.) SERIES 50-200/9.2	12.5	9.2	-	-	-	-	-	-	-	-	50.0	49.0	47.5	45.5	40.5	34.0	-
3(.) SERIES 50-200/11	15	11	-	-	-	-	-	-	-	-	56.0	55.0	54.0	52.0	48.0	42.0	-
3(.) SERIES 50-200/15	20	15	-	-	-	-	-	-	-	-	70.0	69.0	68.0	66.0	62.0	57.0	-

(M) Single phase version only for 3M SERIES

PERFORMANCE CHART 65-80

2 Poles

Model	P ₂		Q = Flow Rate																	
	[HP]	[kW]	l/min m ³ /h	600	700	900	1300	1500	1700	1900	2100	2200	2300	2400	2500	3000	3400	3600	3800	4000
				36	42	54	78	90	102	114	126	132	138	144	150	180	204	216	228	240
H=Head [m]																				
3(.) SERIES 65-125/4.0	5.5	4	19.8	19.0	17.3	13.3	11.0	8.6	6.3	-	-	-	-	-	-	-	-	-	-	-
3(.) SERIES 65-125/5.5	7.5	5.5	-	24.0	22.2	18.0	15.7	13.3	10.8	8.0	-	-	-	-	-	-	-	-	-	-
3(.) SERIES 65-125/7.5	10	7.5	-	29.5	27.8	23.5	21.1	18.7	16.1	13.4	12.0	-	-	-	-	-	-	-	-	-
3(.) SERIES 65-160/7.5	10	7.5	-	30.0	28.6	24.8	22.5	19.9	17.1	14.2	-	-	-	-	-	-	-	-	-	-
3(.) SERIES 65-160/9.2	12.5	9.2	-	34.5	32.8	28.8	26.5	23.9	21.1	18.3	16.8	-	-	-	-	-	-	-	-	-
3(.) SERIES 65-160/11	15	11	-	38.5	37.1	33.1	30.9	28.4	25.8	23.0	21.5	20.0	-	-	-	-	-	-	-	-
3(.) SERIES 65-160/15	20	15	-	45.5	44.0	40.0	37.8	35.3	32.6	29.6	28.0	26.5	-	-	-	-	-	-	-	-
3(.) SERIES 65-200/15	20	15	-	51.0	49.0	44.0	41.5	38.4	35.3	31.8	30.0	-	-	-	-	-	-	-	-	-
3(.) SERIES 65-200/18.5	25	18.5	-	58.5	56.5	51.5	49.0	46.0	43.0	39.7	38.0	36.3	-	-	-	-	-	-	-	-
3(.) SERIES 65-200/22	30	22	-	65.5	64.0	59.5	57.0	54.0	51.0	48.0	46.5	45.0	-	-	-	-	-	-	-	-
3(.) SERIES 65-250/30	40	30	-	-	77.0	73.5	71.0	68.0	64.5	60.0	57.5	55.0	52.0	-	-	-	-	-	-	-
3(.) SERIES 65-250/37	50	37	-	-	88.0	85.5	83.0	80.5	77.5	74.0	72.0	70.0	67.5	65.0	-	-	-	-	-	-
3(.) SERIES 80-160/11	15	11	-	-	-	27.3	26.4	25.4	24.2	23.0	22.4	21.8	21.1	20.4	16.4	12.5	-	-	-	-
3(.) SERIES 80-160/15R	20	15	-	-	-	30.5	29.7	28.8	27.7	26.5	25.9	25.3	24.6	24.0	20.1	16.5	14.5	-	-	-
3(.) SERIES 80-160/15	20	15	-	-	-	34.0	33.3	32.5	31.5	30.5	30.0	29.4	28.8	28.1	24.4	21.0	19.1	17.0	-	-
3(.) SERIES 80-160/18.5	25	18.5	-	-	-	39.0	38.4	37.6	36.7	35.7	35.2	34.7	34.1	33.5	30.0	26.4	24.4	22.3	20.0	-
3(.) SERIES 80-200/22	30	22	-	-	-	48.0	47.0	45.5	44.5	43.0	42.0	41.0	40.0	39.0	33.2	27.8	25.0	-	-	-
3(.) SERIES 80-200/30	40	30	-	-	-	58.5	58.0	57.0	56.0	54.5	54.0	53.0	52.0	51.0	46.5	41.5	39.0	36.1	33.0	-
3(.) SERIES 80-200/37	50	37	-	-	-	64.0	63.0	62.0	61.0	59.5	59.0	58.0	57.5	56.5	51.5	47.0	44.5	41.5	38.5	-
3(.) SERIES 80-250/37	50	37	-	-	-	71.5	70.5	68.5	66.5	64.0	63.0	61.5	60.0	58.5	48.5	38.0	-	-	-	-
3(.) SERIES 80-250/45	60	45	-	-	-	82.5	81.5	80.0	78.0	76.0	75.0	73.5	72.5	71.0	62.0	53.0	48.0	42.5	-	-
3(.) SERIES 80-250/55	75	55	-	-	-	93.5	92.5	91.5	90.0	88.5	87.5	86.5	85.5	84.0	76.5	68.5	64.5	60.0	55.0	-



3 - 3L SERIES

CENTRIFUGAL ELECTRIC PUMPS STANDARDISED IN COMPLIANCE WITH EN 733 (EX DIN 24255)

PERFORMANCE CURVES 3(L)M-3(L)S-3(L)P 32 SERIES at 2900 min⁻¹ (according to ISO 9906 Attachment A)

2 Poles

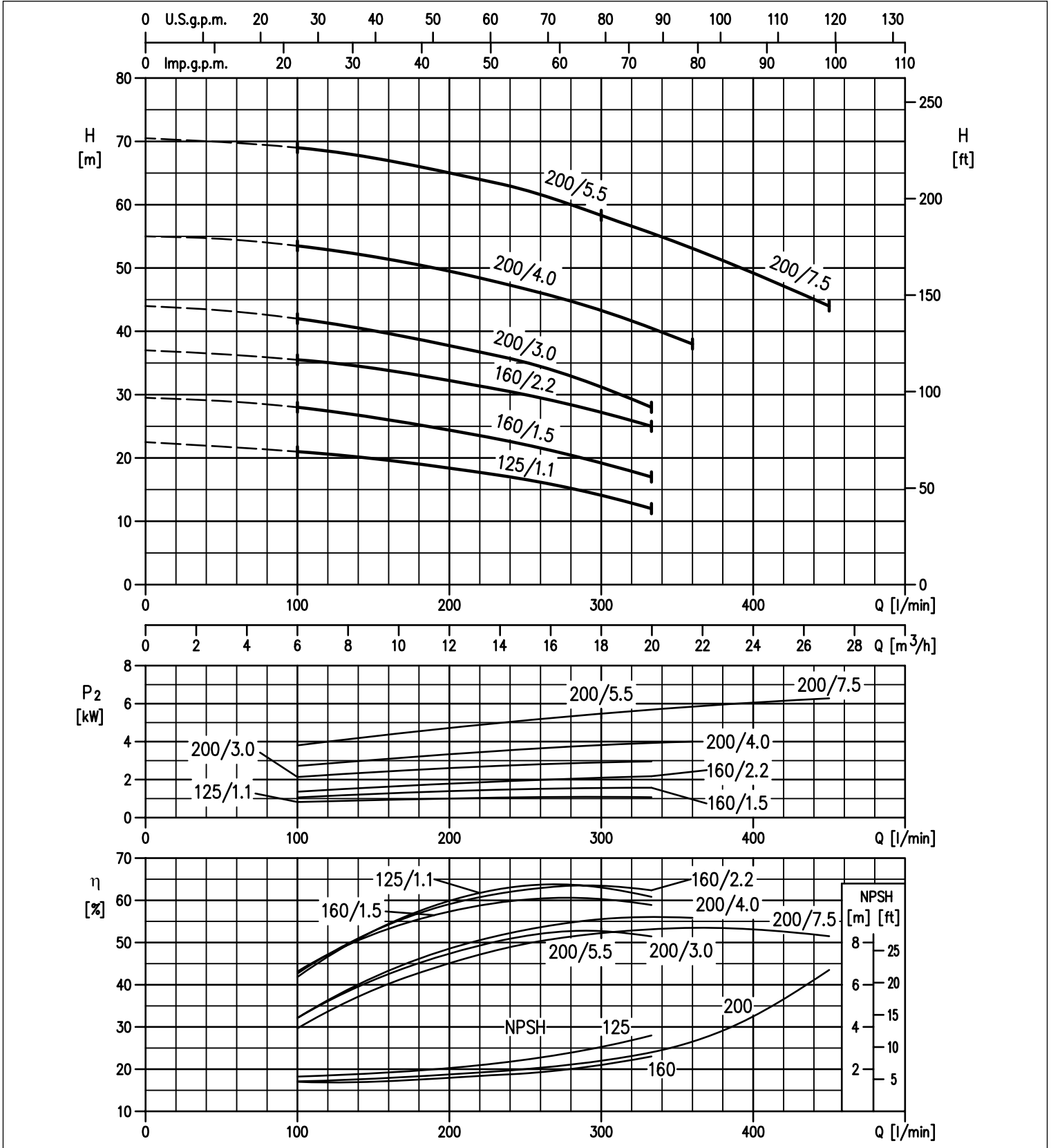

The content of this publication should not be considered mandatory. EBARA Pumps Europe S.p.A. reserves the right to change the content without prior notice.



3 - 3L SERIES

CENTRIFUGAL ELECTRIC PUMPS STANDARDISED IN COMPLIANCE WITH EN 733 (EX DIN 24255)

PERFORMANCE CURVES 3(L)M-3(L)S-3(L)P 40 SERIES at 2900 min⁻¹ (according to ISO 9906 Attachment A)

2 Poles

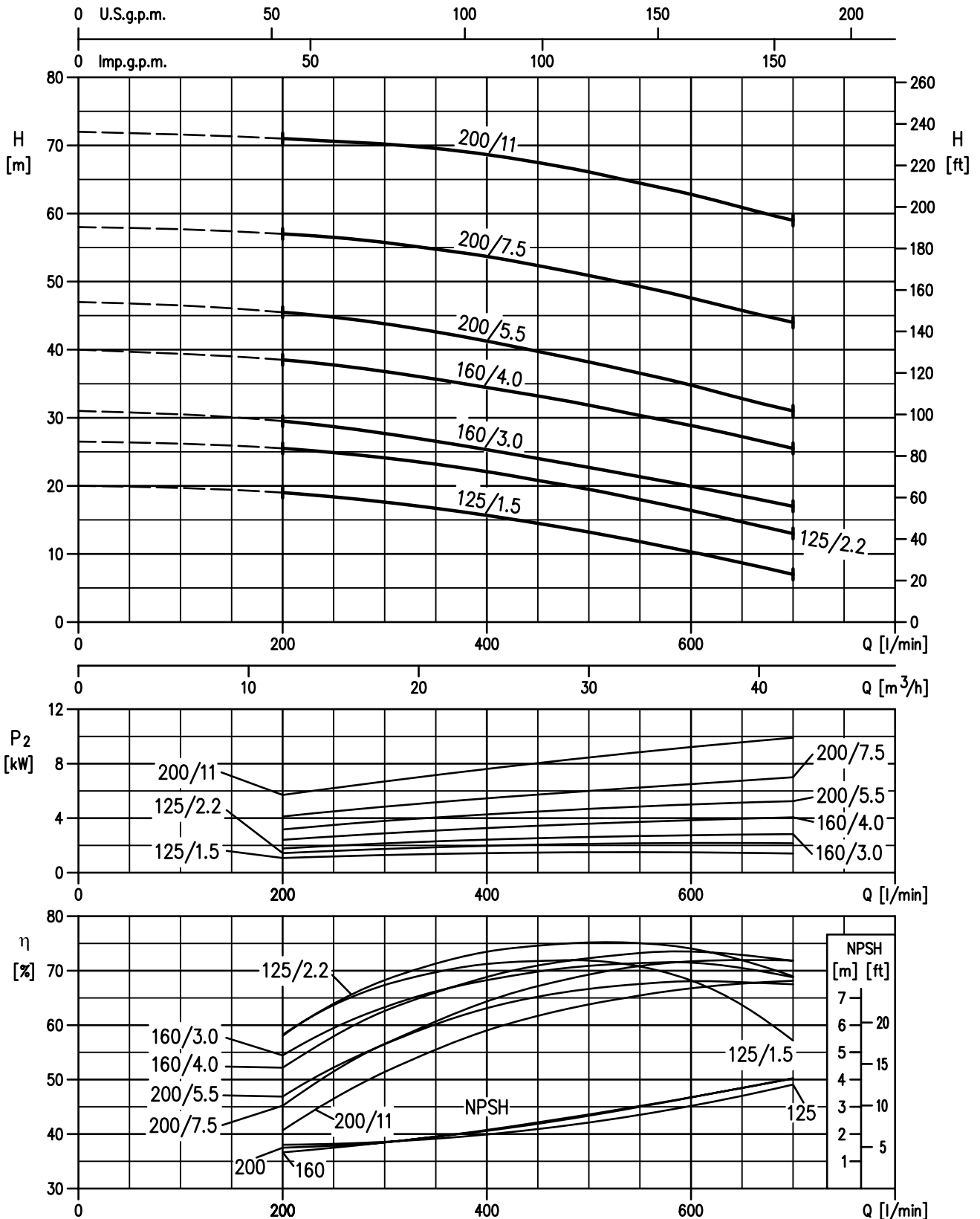

The content of this publication should not be considered mandatory. EBARA Pumps Europe S.p.A. reserves the right to change the content without prior notice.



3 - 3L SERIES

CENTRIFUGAL ELECTRIC PUMPS STANDARDISED IN COMPLIANCE WITH EN 733 (EX DIN 24255)

PERFORMANCE CURVES 3(L)M-3(L)S-3(LP) 50 SERIES at 2900 min⁻¹ (according to ISO 9906 Attachment A)

2 Poles

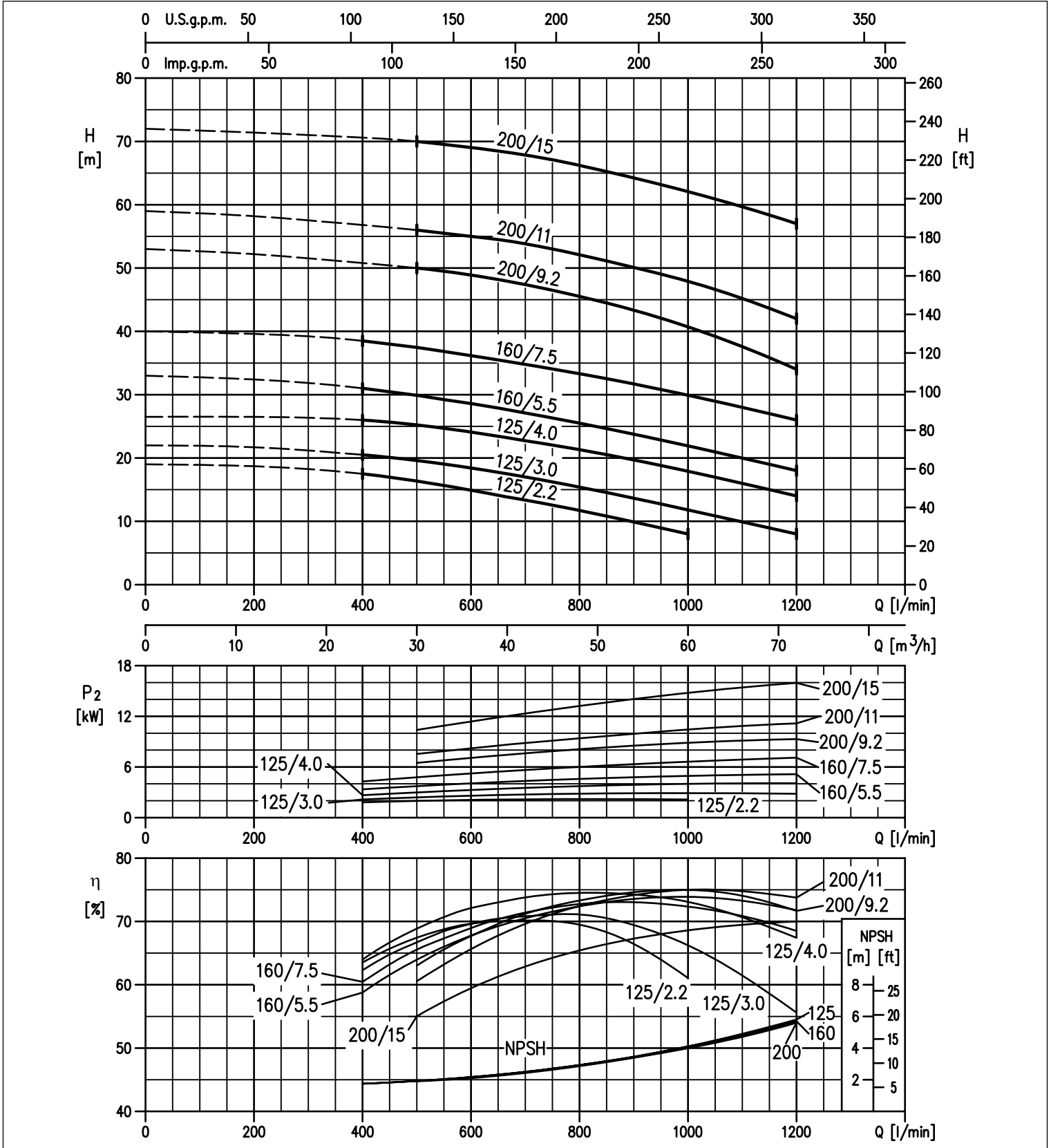

The content of this publication should not be considered mandatory. EBARA Pumps Europe S.p.A. reserves the right to change the content without prior notice.



3 - 3L SERIES

CENTRIFUGAL ELECTRIC PUMPS STANDARDISED IN COMPLIANCE WITH EN 733 (EX DIN 24255)

PERFORMANCE CURVES 3(L)M-3(L)S-3(L)P 65 SERIES at 2900 min⁻¹ (according to ISO 9906 Attachment A)

2 Poles

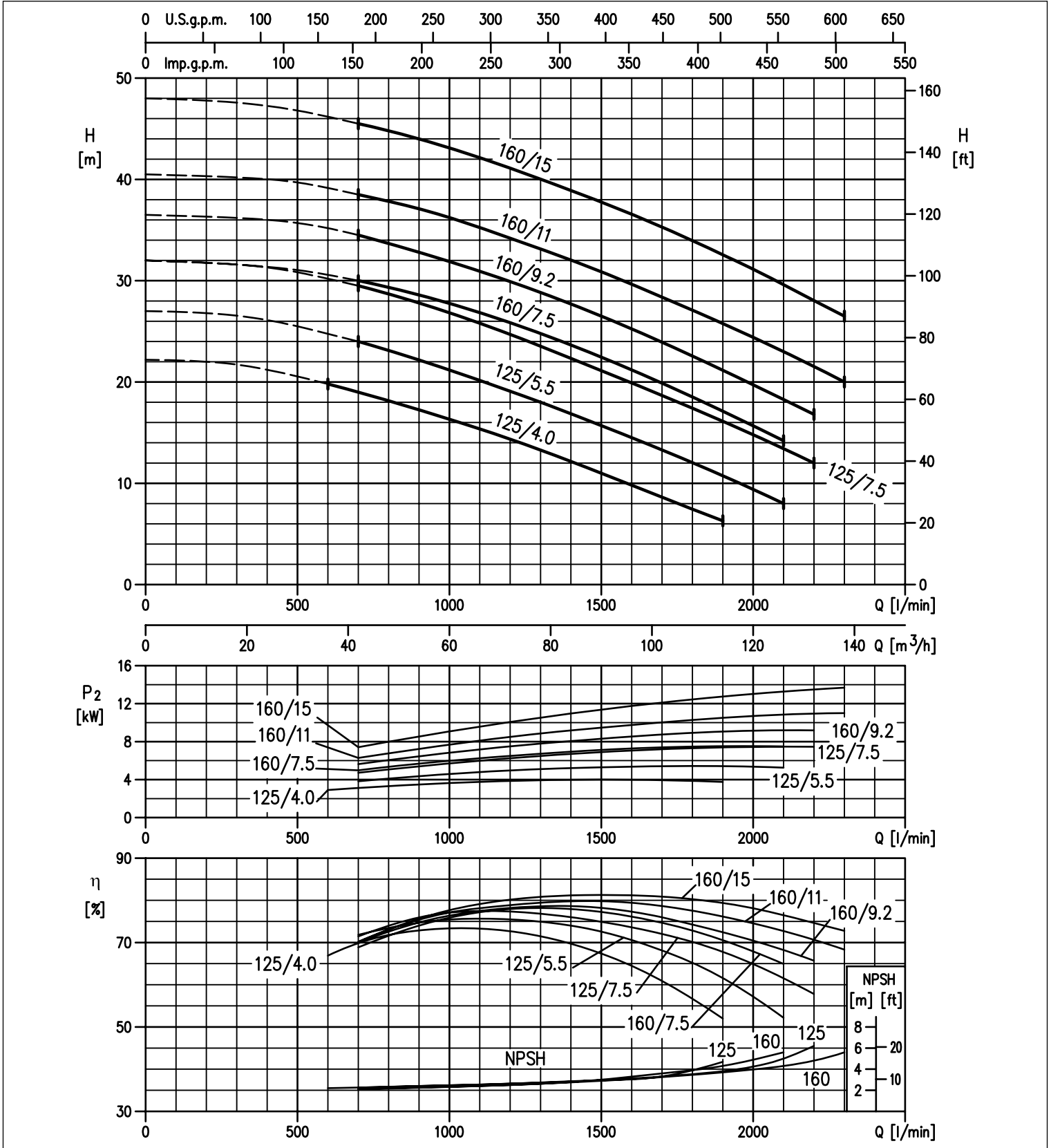

The content of this publication should not be considered mandatory. EBARA Pumps Europe S.p.A. reserves the right to change the content without prior notice.



3 - 3L SERIES

CENTRIFUGAL ELECTRIC PUMPS STANDARDISED IN COMPLIANCE WITH EN 733 (EX DIN 24255)

PERFORMANCE CURVES 3L 65 SERIES at 2900 min⁻¹ (according to ISO 9906 Attachment A)

2 Poles

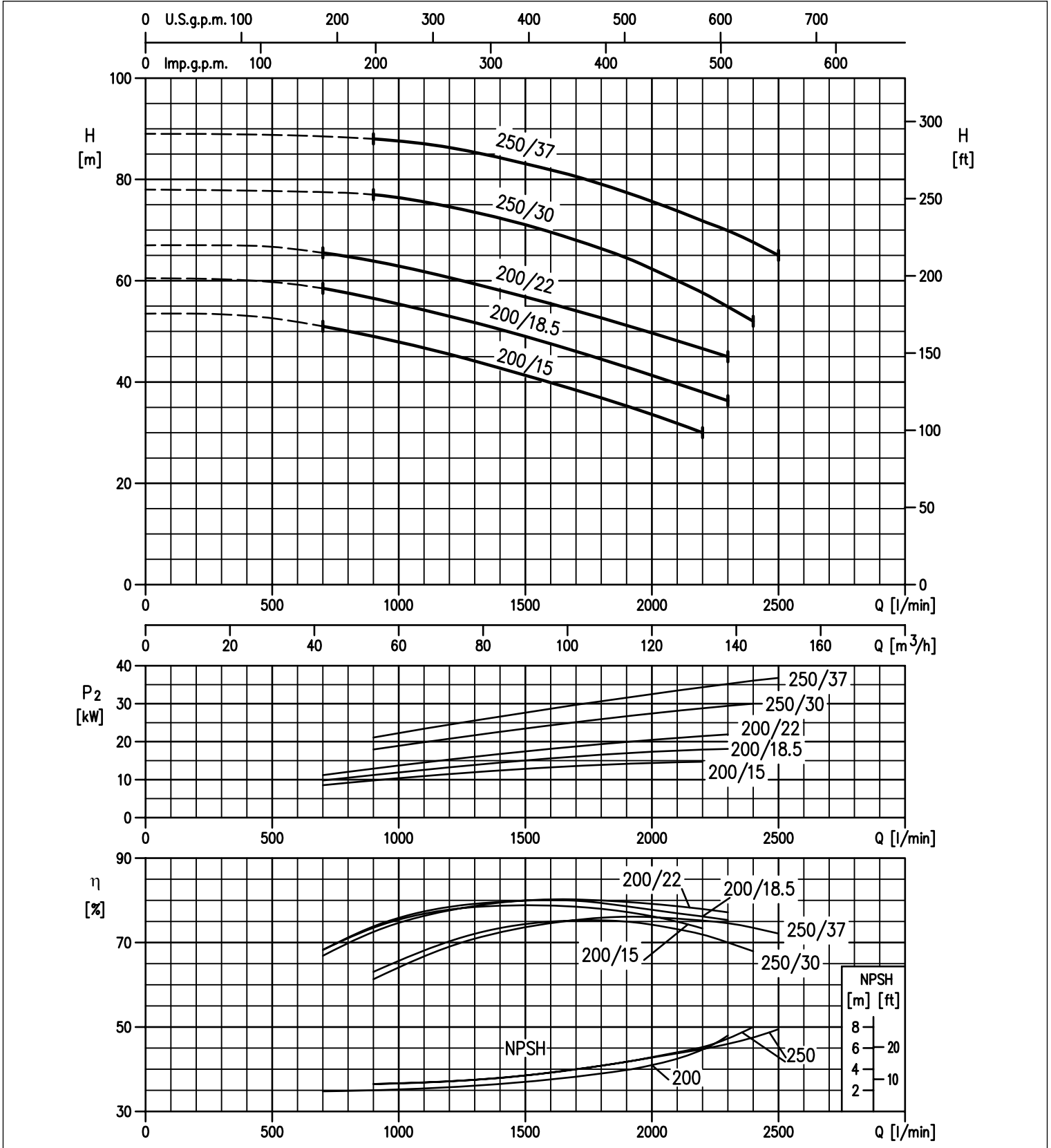

The content of this publication should not be considered mandatory. EBARA Pumps Europe S.p.A. reserves the right to change the content without prior notice.



3 - 3L SERIES

CENTRIFUGAL ELECTRIC PUMPS STANDARDISED IN COMPLIANCE WITH EN 733 (EX DIN 24255)

PERFORMANCE CURVES 3L 80 SERIES at 2900 min⁻¹ (according to ISO 9906 Attachment A)

2 Poles

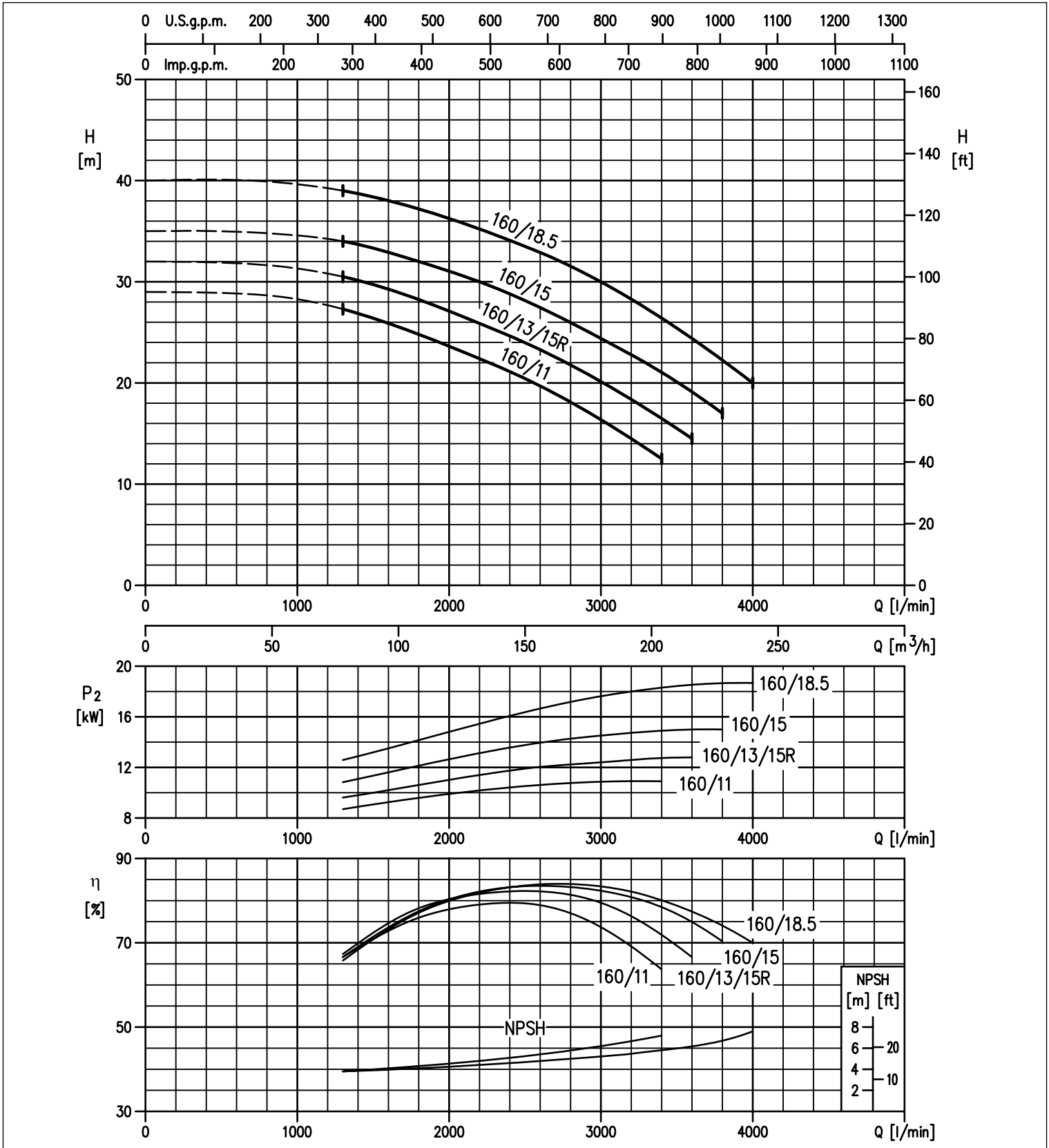

The content of this publication should not be considered mandatory. EBARA Pumps Europe S.p.A. reserves the right to change the content without prior notice.



3 - 3L SERIES

CENTRIFUGAL ELECTRIC PUMPS STANDARDISED IN COMPLIANCE WITH EN 733 (EX DIN 24255)

PERFORMANCE CURVES 3L 80 SERIES at 2900 min⁻¹ (according to ISO 9906 Attachment A)

2 Poles

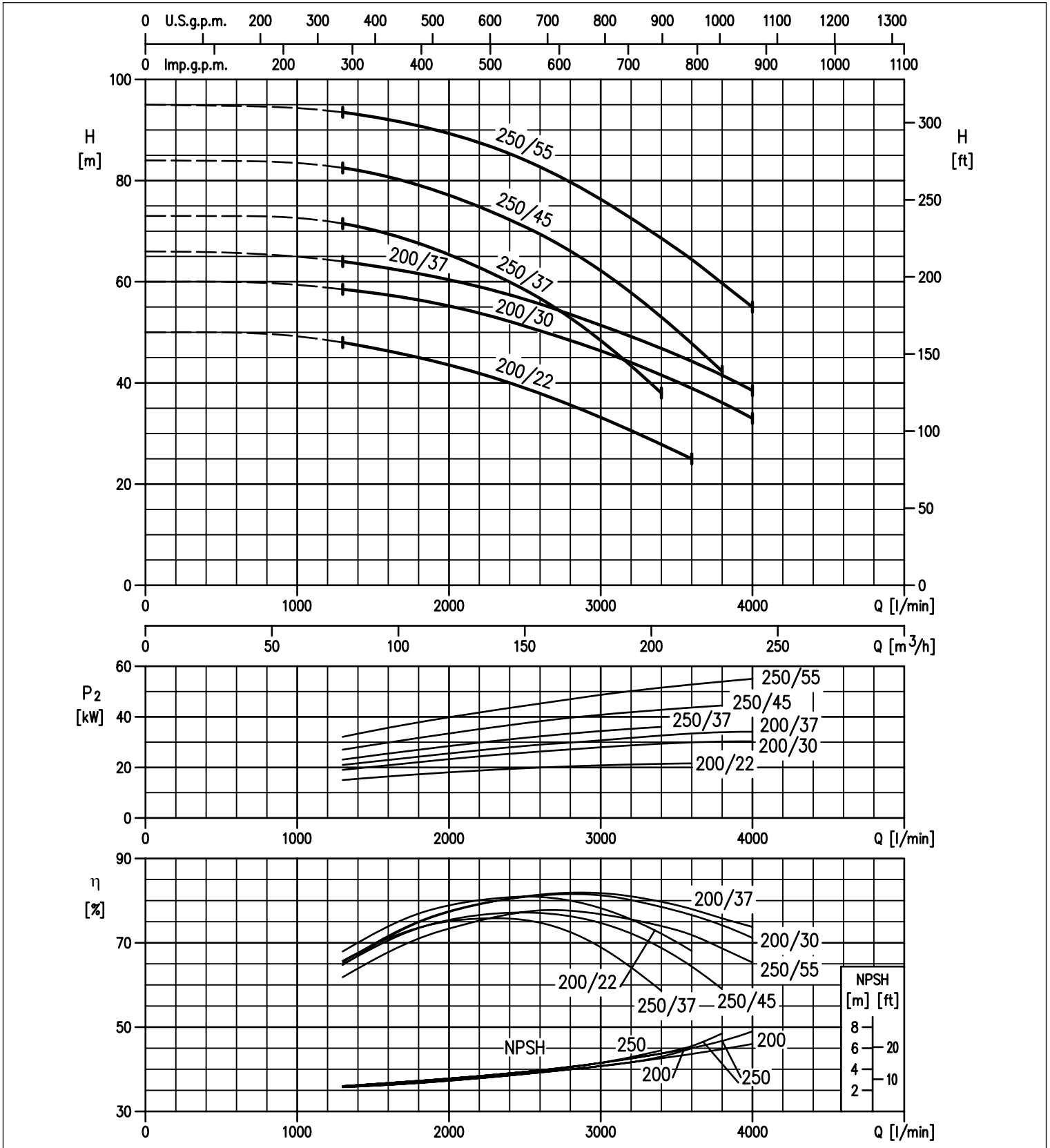

The content of this publication should not be considered mandatory. EBARA Pumps Europe S.p.A. reserves the right to change the content without prior notice.

3 - 3L SERIES

CENTRIFUGAL ELECTRIC PUMPS STANDARDISED IN COMPLIANCE WITH EN 733
(EX DIN 24255)

3(L)M 32, 40, 50, 65 - up to 11 kW

2 Poles

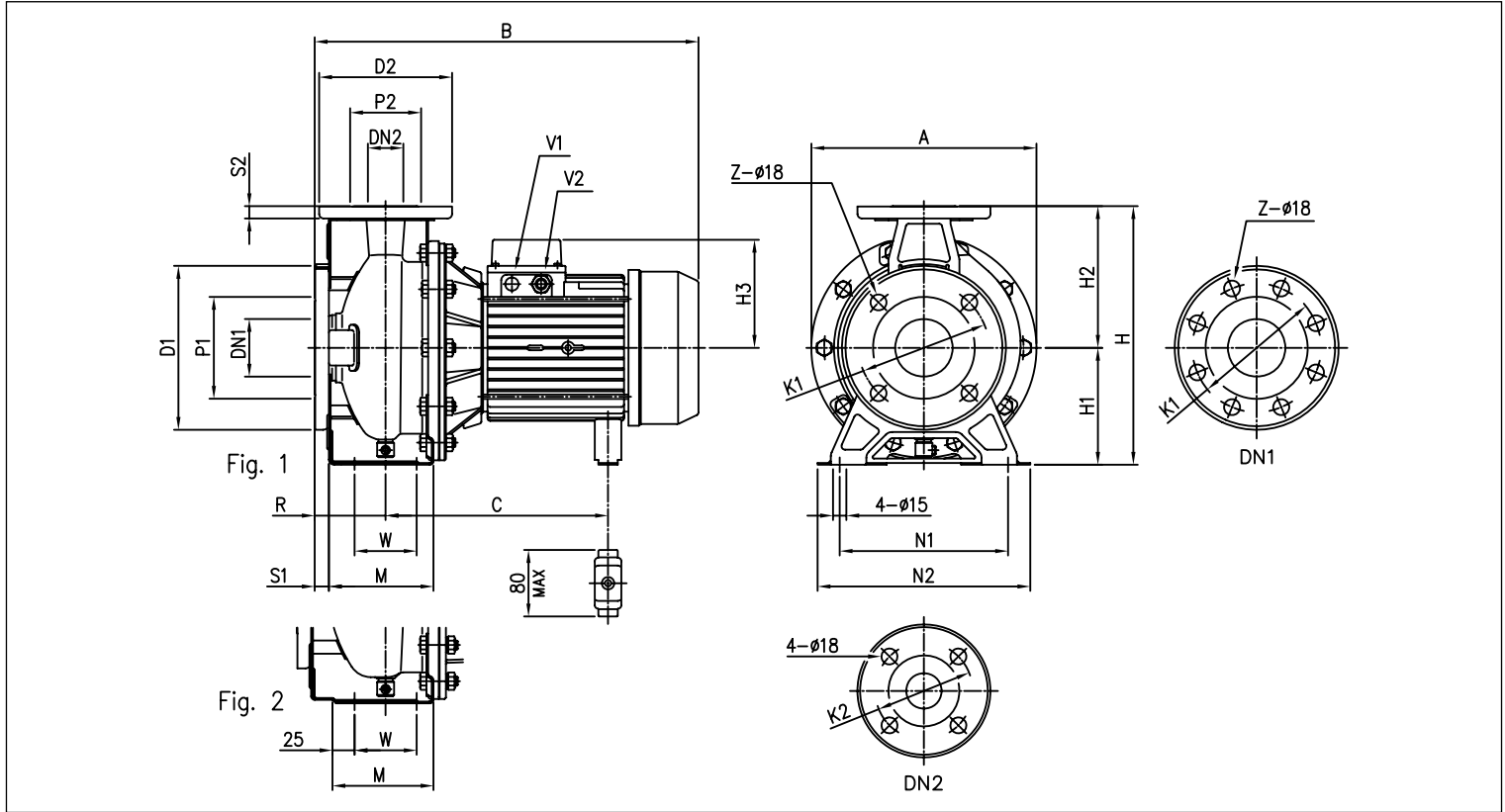

DIMENSIONAL TABLE

Modello	Dimensioni [mm]																			Peso [kg]													
	DN1 Ø	P1 Ø	K1 Ø	D1 Ø	S1	Z [1] [2]	DN2 Ø	P2 Ø	K2 Ø	D2 Ø	S2	Fig.	H	H1	H2	H3 [4] [3]	R	W	M	N1	N2	A	B [4] [3]	C [3]	V1 [3]	V2 [1]	[4]	[3]					
32-125/1.1 (M)	50	95	125	165	16	4	-	32	75	100	140	14	1	252	112	140	141	119	80	70	114	140	190	213	408	431	219÷230	232	-	PG 13.5	M20x1.5	19.6	24.1
32-160/1.5 (M)	50	95	125	165	16	4	-	32	75	100	140	14	1	292	132	160	141	119	80	70	118	190	240	254	408	431	219÷230	232	-	PG 13.5	M20x1.5	22.5	27.0
32-160/2.2 (M)	50	95	125	165	16	4	-	32	75	100	140	14	1	292	132	160	141	119	80	70	118	190	240	254	408	431	219÷230	232	-	PG 13.5	M20x1.5	27.7	28.0
32-200/3.0	50	95	125	165	16	4	-	32	75	100	140	14	1	340	160	180	-	124	80	70	119	190	240	296	-	471	-	244÷255	-	PG 13.5	-	-	35.1
32-200/4.0	50	95	125	165	16	4	-	32	75	100	140	14	1	340	160	180	-	141	80	70	119	190	240	296	-	494	-	253	-	PG 16	-	-	38.2
32-200/5.5	50	95	125	165	16	4	-	32	75	100	140	14	1	340	160	180	-	150	80	70	119	190	240	296	-	519	-	275	M20x1.5	PG 16	-	-	52.2
32-200/7.5	50	95	125	165	16	4	-	32	75	100	140	14	1	340	160	180	-	150	80	70	119	190	240	296	-	539	-	275	PG 13.5	PG 16	-	-	60.1
40-125/1.5 (M)	65	115	145	185	16	4	-	40	80	110	150	14	1	252	112	140	141	119	80	70	114	160	210	213	408	431	219÷230	232	-	PG 13.5	M20x1.5	20.1	24.6
40-125/2.2 (M)	65	115	145	185	16	4	-	40	80	110	150	14	1	252	112	140	141	119	80	70	114	160	210	213	408	431	219÷230	232	-	PG 13.5	M20x1.5	25.8	26.1
40-160/3.0	65	115	145	185	16	4	-	40	80	110	150	14	1	292	132	160	-	124	80	70	118	190	240	254	-	471	-	244÷255	-	PG 13.5	-	-	26.6
40-160/4.0	65	115	145	185	16	4	-	40	80	110	150	14	1	292	132	160	-	141	80	70	118	190	240	254	-	494	-	253	-	PG 16	-	-	40.8
40-200/5.5	65	115	145	185	16	4	-	40	80	110	150	14	2	340	160	180	-	150	100	70	115	212	265	296	-	539	-	275	M20x1.5	PG 16	-	-	52.5
40-200/7.5	65	115	145	185	16	4	-	40	80	110	150	14	2	340	160	180	-	150	100	70	115	212	265	296	-	559	-	275	PG 13.5	PG 16	-	-	59.3
40-200/11	65	115	145	185	16	4	-	40	80	110	150	14	2	340	160	180	-	178	100	70	115	212	265	296	-	595	-	359	PG 13.5	PG 21	-	-	69.6
50-125/2.2 (M)	65	115	145	185	16	4	-	50	95	125	165	16	2	292	132	160	141	119	100	70	114	190	240	254	428	451	219÷230	232	-	PG 13.5	M20x1.5	29.4	32.0
50-125/3.0	65	115	145	185	16	4	-	50	95	125	165	16	2	292	132	160	-	124	100	70	114	190	240	254	-	491	-	244÷255	-	PG 13.5	-	-	30.9
50-125/4.0	65	115	145	185	16	4	-	50	95	125	165	16	2	292	132	160	-	141	100	70	114	190	240	254	-	514	-	253	-	PG 16	-	-	40.9
50-160/5.5	65	115	145	185	16	4	-	50	95	125	165	16	2	340	160	180	-	150	100	70	115	212	265	296	-	539	-	275	M20x1.5	PG 16	-	-	46.5
50-160/7.5	65	115	145	185	16	4	-	50	95	125	165	16	2	340	160	180	-	150	100	70	115	212	265	296	-	559	-	275	PG 13.5	PG 16	-	-	58.6
50-200/9.2	65	115	145	185	16	4	-	50	95	125	165	16	2	360	160	200	-	178	100	70	115	212	265	296	-	595	-	359	PG 13.5	PG 21	-	-	63.9
50-200/11	65	115	145	185	16	4	-	50	95	125	165	16	2	360	160	200	-	178	100	70	115	212	265	296	-	595	-	359	PG 13.5	PG 21	-	-	69.6
65-125/4	80	134	160	200	18	8	4	65	115	145	185	16	2	340	160	180	-	141	100	95	140	212	280	254	-	514	-	253	-	PG 16	-	-	37.7
65-125/5.5	80	134	160	200	18	8	4	65	115	145	185	16	2	340	160	180	-	150	100	95	140	212	280	254	-	539	-	275	M20x1.5	PG 16	-	-	48.7
65-125/7.5	80	134	160	200	18	8	4	65	115	145	185	16	2	340	160	180	-	150	100	95	140	212	280	254	-	559	-	275	PG 13.5	PG 16	-	-	52.1
65-160/7.5	80	134	160	200	18	8	4	65	115	145	185	16	2	360	160	200	-	150	100	95	140	212	280	296	-	559	-	275	PG 13.5	PG 16	-	-	55.3
65-160/9.2	80	134	160	200	18	8	4	65	115	145	185	16	2	360	160	200	-	178	100	95	140	212	280	296	-	595	-	359	PG 13.5	PG 21	-	-	61.0
65-160/11	80	134	160	200	18	8	4	65	115	145	185	16	2	360	160	200	-	178	100	95	140	212	280	296	-	595	-	359	PG 13.5	PG 21	-	-	67.4

[1] Standard [2] On request
[3] Three-phase only [4] Single phase only

3 - 3L SERIES

CENTRIFUGAL ELECTRIC PUMPS STANDARDISED IN COMPLIANCE WITH EN 733
(EX DIN 24255)

3(L)M 50, 65 - 15 ÷ 22 kW

2 Poles

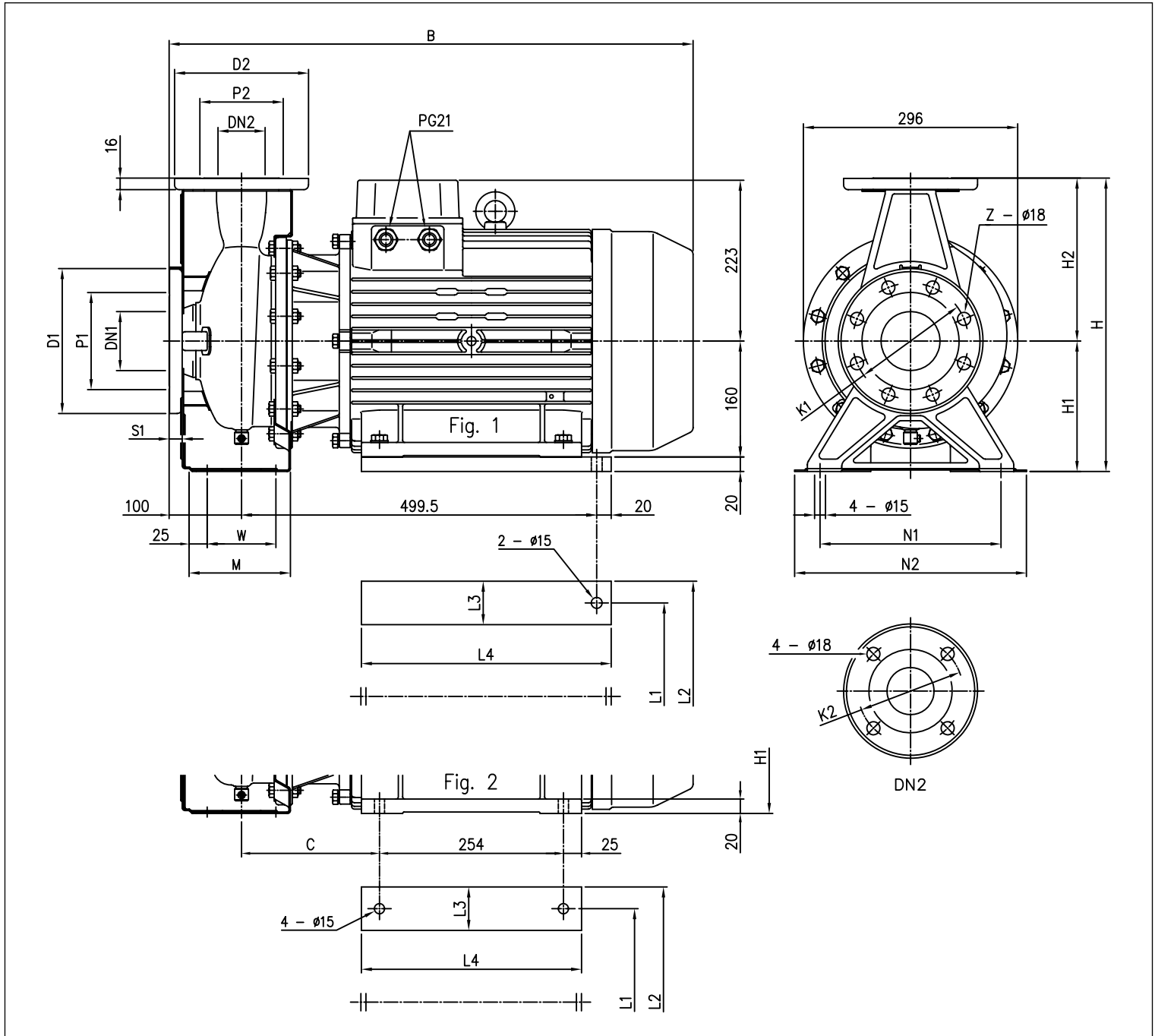

DIMENSIONAL TABLE

Modello	Dimensioni [mm]																				Peso [kg]					
	DN1 Ø	P1 Ø	K1 Ø	D1 Ø	S1	Z [1]	Z [2]	DN2 Ø	P2 Ø	K2 Ø	D2 Ø	Fig.	H	H1	H2	W	M	N1	N2	B		C	L1	L2	L3	L4
50-200/15	65	115	145	185	16	4	-	50	95	125	165	2	360	160	200	70	115	212	265	723	190,5	254	318	65	304	105,1
65-160/15	80	134	160	200	18	8	4	65	115	145	185	2	360	160	200	95	140	212	280	732	199,5	254	318	65	304	107,1
65-200/15	80	134	160	200	18	8	4	65	115	145	185	1	405	180	225	95	140	250	320	732	-	254	314	60	345	110,1
65-200/18,5	80	134	160	200	18	8	4	65	115	145	185	1	405	180	225	95	140	250	320	732	-	254	314	60	345	125,3
65-200/22	80	134	160	200	18	8	4	65	115	145	185	1	405	180	225	95	140	250	320	732	-	254	314	60	345	136,1

[1] Standard [2] On request

The content of this publication should not be considered mandatory. EBARA Pumps Europe S.p.A. reserves the right to change the content without prior notice.

3 - 3L SERIES

CENTRIFUGAL ELECTRIC PUMPS STANDARDISED IN COMPLIANCE WITH EN 733
(EX DIN 24255)

3LM 80-160 - 11 kW

2 Poles

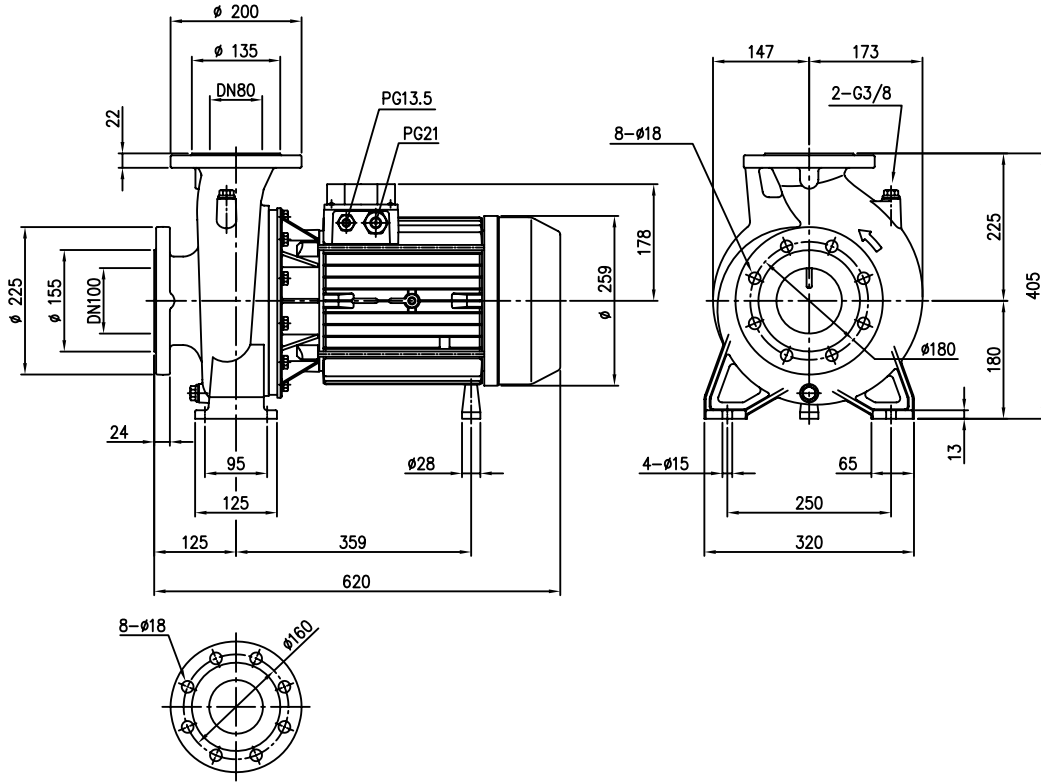

3LM 80-160 / 15R / 15 / 18.5 kW

2 Poles

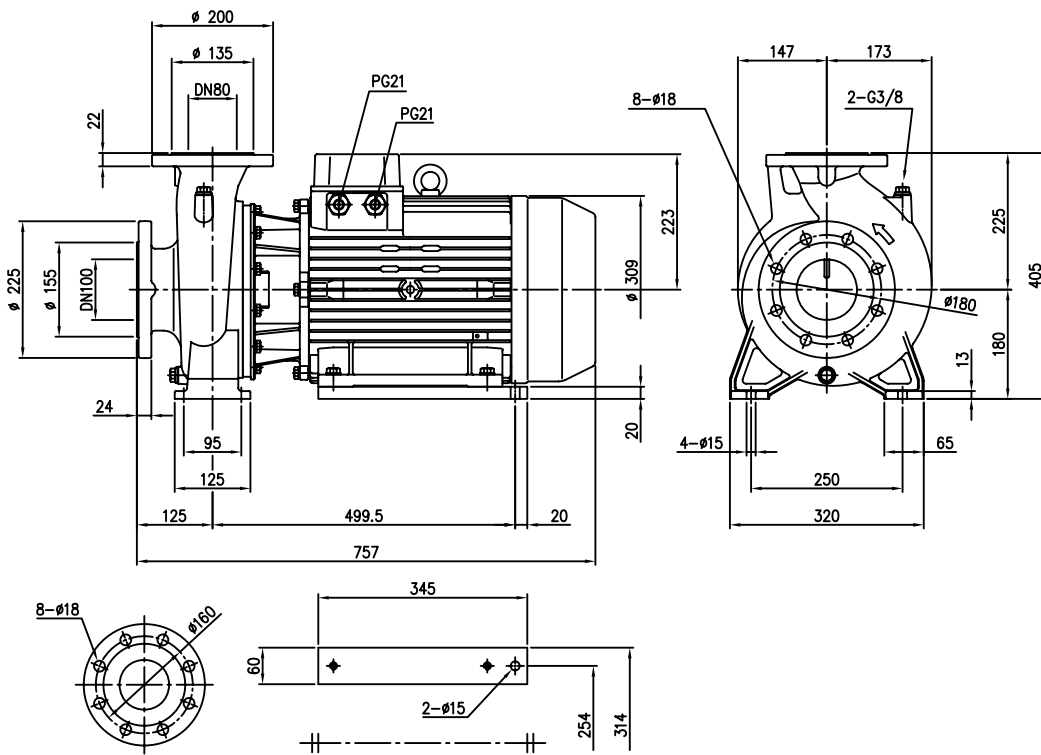

The content of this publication should not be considered mandatory. EBARA Pumps Europe S.p.A. reserves the right to change the content without prior notice.

3 - 3L SERIES

CENTRIFUGAL ELECTRIC PUMPS STANDARDISED IN COMPLIANCE WITH EN 733
(EX DIN 24255)

SECTIONAL VIEW 3(L)M 32, 40, 50, 65 SERIES - up to 11 kW

2 Poles

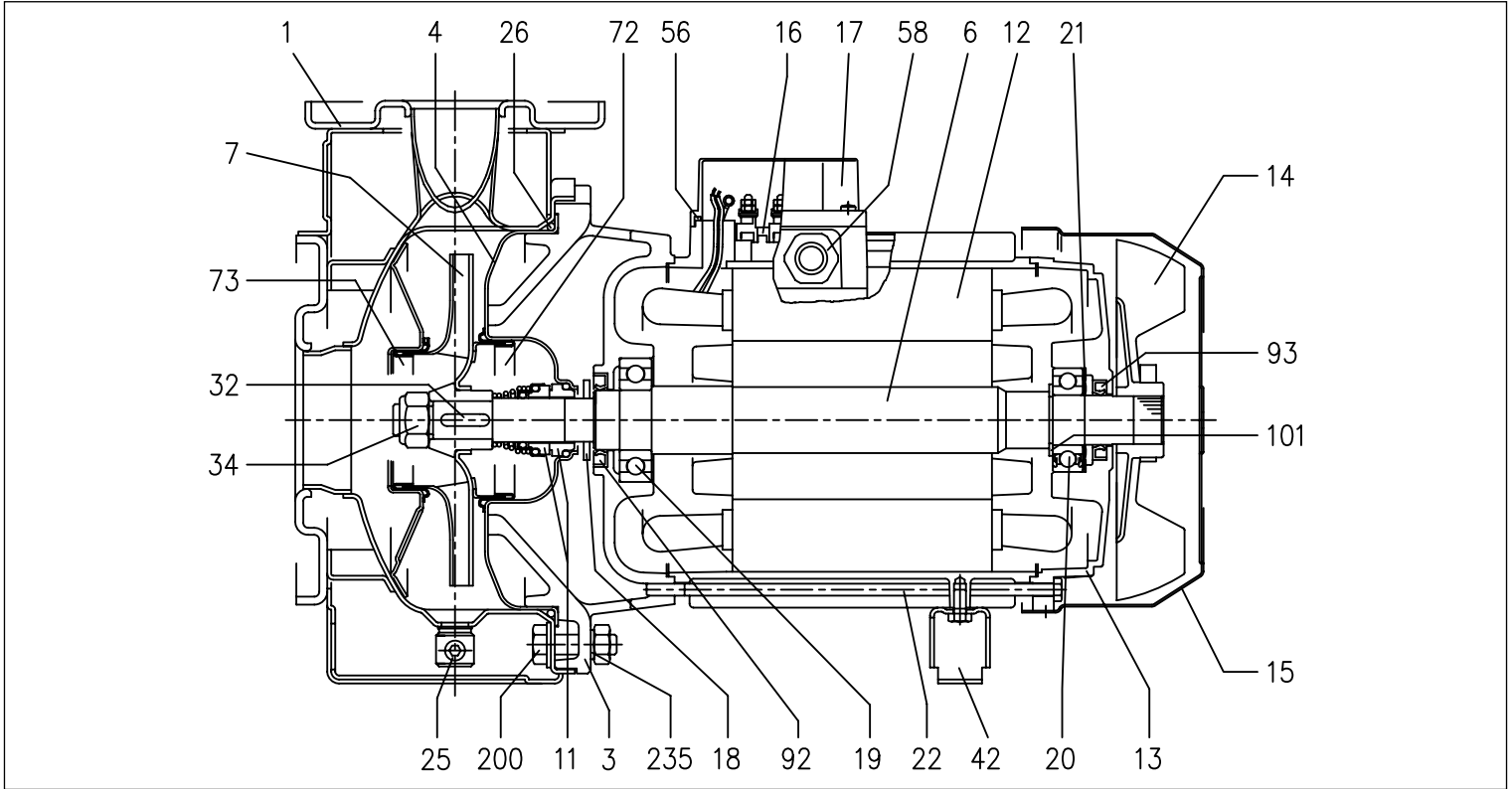

SECTIONAL VIEW 3(L)M 32, 40, 50, 65 SERIES - of 15 kW and over

2 Poles

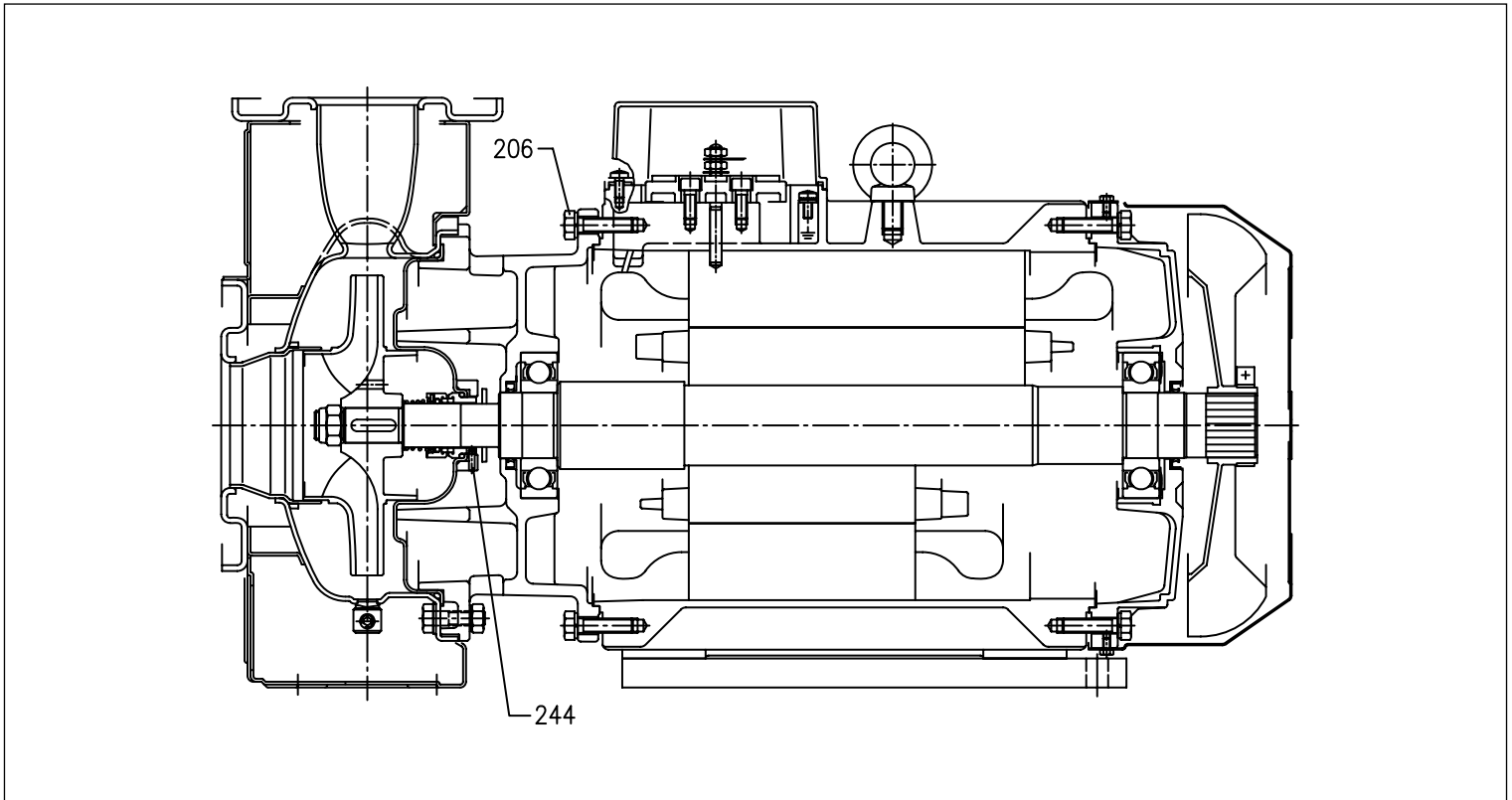

The content of this publication should not be considered mandatory. EBARA Pumps Europe S.p.A. reserves the right to change the content without prior notice.

3 - 3L SERIES

CENTRIFUGAL ELECTRIC PUMPS STANDARDISED IN COMPLIANCE WITH EN 733 (EX DIN 24255)

MATERIALS TABLE

Ref.	Name	Materials	
		3M	3LM
001	Pump casing	EN 1.4301 (AISI 304)	EN 1.4404 (AISI 316L)
003	Motor bracket		[4]
004	Casing cover	EN 1.4301 (AISI 304)	EN 1.4404 (AISI 316L)
006	Shaft	EN 1.4301 (AISI 304)	EN 1.4404 (AISI 316L)
007	Impeller	EN 1.4301 (AISI 304)	EN 1.4404 (AISI 316L)
011	Mechanical seal std	Carbon/Ceramic/NBR	Silicon Carbide/Silicon Carbide/FKM
012	Motor frame		-
013	Motor cover		Aluminium
014	Fan		PA
015	Fan cover		Galvanised steel Fe P04
016	Terminal Box		-
017	Terminal Box cover		Aluminium (three phase version)
018	Splash washer	NBR	-
019	Bearing (pump side)		-
020	Bearing (motor side)		-
021	Adjustment ring		Steel C70
022	Tie-rod		Galvanised steel Fe 42
	Screw		Galvanised steel
025	Plug		EN 1.4401 (AISI 316) / PTFE
026	O-Ring	NBR	FKM
032	Key		EN 1.4401 (AISI 316)
034	Impeller nut	EN 1.4301 (AISI 304)	EN 1.4404 (AISI 316L)
042	Motor support		Aluminium / Galvanised steel
056	Terminal box gasket		NBR
058	Cable gland		-
072	Casing ring [1]	EN 1.4301 (AISI 304)	EN 1.4404 (AISI 316L)
073	Casing ring	EN 1.4301 (AISI 304)	EN 1.4404 (AISI 316L)
092	Seal ring	-	-
093	Seal ring	-	-
101	Seeger ring		Carbon steel TC 80
200	Screw (pump body)		Stainless steel A2 70 class ISO 3506/1
206	Support screw [2]		Galvanised steel
244	Plug [3]		EN 1.4301 (AISI 304)

[1]= For 32-200/3, 32-200/4, 32-200/5.5, 40-200/5.5, 40-200/7.5, 40-200/11, 50-160/5.5, 50-160/7.5, 50-200/9.2, 50-200/11, 50-200/15

[2]= For 15 kW and over

[3]= Only for 65-160/15 and 65-200

[4]= Cast iron EN-GJL-200-EN 1561 for 32-200/3 and for models with 15, 18,5 and 22 kW motors

Aluminium AL-EN-1706-AC-46000-D for the other models

3 - 3L SERIES

CENTRIFUGAL ELECTRIC PUMPS STANDARDISED IN COMPLIANCE WITH EN 733
(EX DIN 24255)

SECTIONAL VIEW 3LM 80-160/11 SERIES

2 Poles

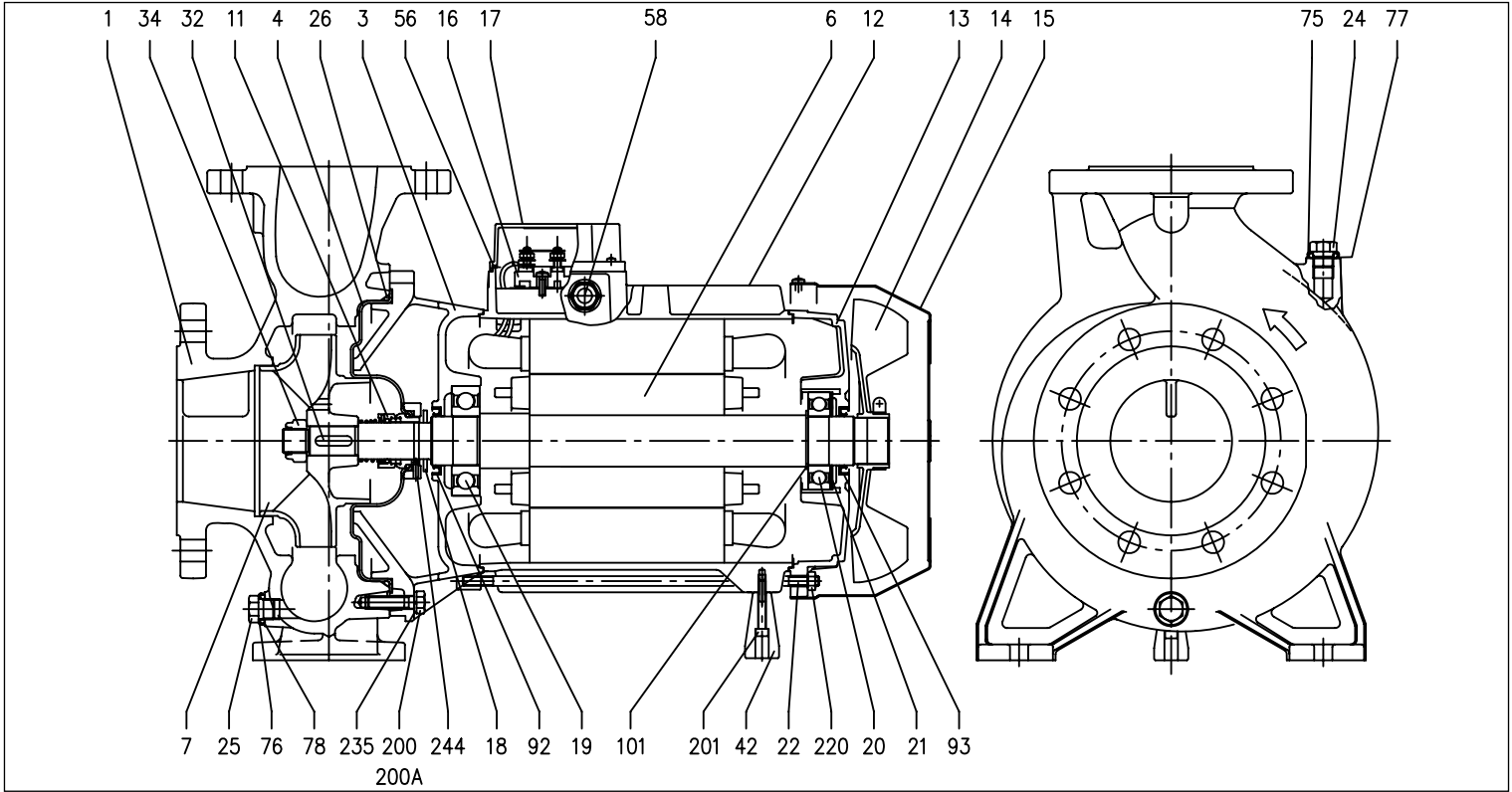

SECTIONAL VIEW 3LM 80-160/15R SERIES

2 Poles

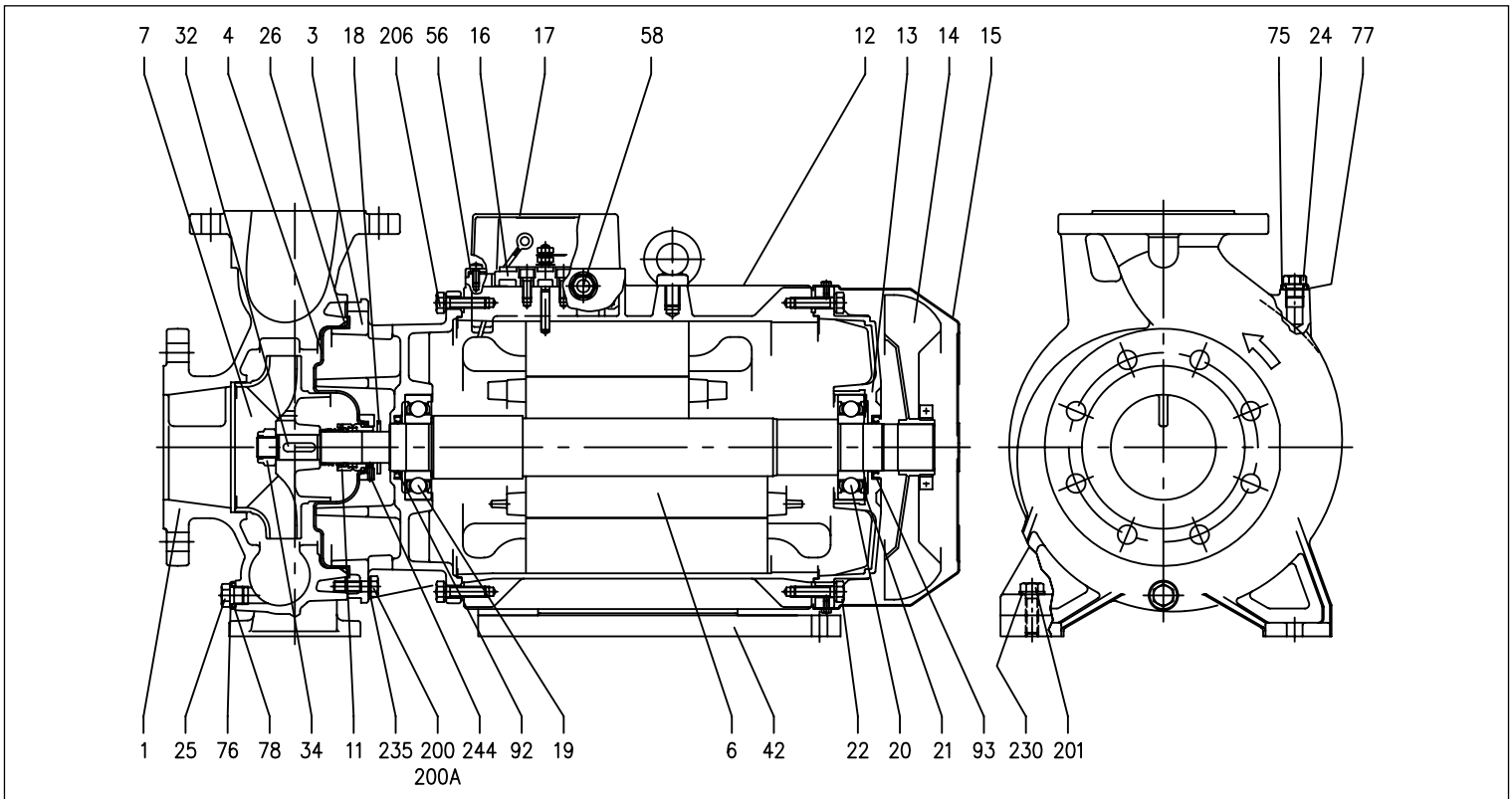

The content of this publication should not be considered mandatory. EBARA Pumps Europe S.p.A. reserves the right to change the content without prior notice.

3 - 3L SERIES

CENTRIFUGAL ELECTRIC PUMPS STANDARDISED IN COMPLIANCE WITH EN 733 (EX DIN 24255)

MATERIALS TABLE

Ref.	Name	Materials	Ref.	Name	Materials
001	Pump casing	EN 1.4401 (AISI 316)	032	Key	EN 1.4404 (AISI 316L)
003	Motor bracket	Cast iron EN-GJL-200-EN 1561	034	Impeller nut	Aluminium
004	Casing cover	EN 1.4404 (AISI 316L)	042	Motor support	Aluminium
006	Shaft	EN 1.4404 (AISI 316L) Part in contact with the liquid	056	Terminal box gasket	NBR
007	Impeller	EN 1.4401 (AISI 316)	058	Cable gland	-
011	Mechanical seal	Silicon Carbide/Silicon Carbide/FKM	075	Washer	EN 1.4404 (AISI 316L)
012	Motor frame	-	076	Washer	EN 1.4404 (AISI 316L)
013	Motor cover	Aluminium	077	O-Ring	FKM
014	Fan	PA	078	O-Ring	
015	Fan cover	Galvanised steel Fe P04	092	Seal ring (11 kW, 15-18.5 kW)	-
016	Terminal Box	-	093	Seal ring (11 kW, 15-18.5 kW)	-
017	Terminal Box cover	Aluminium	101	Seeger ring (only for 11 kW)	Carbon steel TC 80
018	Splash washer	NBR	200	Screw (pump body)	Stainless steel A2-70/1 class ISO 3506/1
019	Bearing (pump side)	-	201	Screw (11 kW, 15-18.5 kW)	Stainless steel A2-70/1 class ISO 3506/1
020	Bearing (motor side)	-	206	Motor bracket screw (only for 15-18.5 kW)	Galvanised steel
021	Adjustment ring	Steel C70	220	Tie-rod nut (only for 11 kW)	Galvanised steel
022	Tie-rod	Galvanised steel	230	Washer (15-18.5 kW)	Galvanised steel
024	Plug	EN 1.4404 (AISI 316L)	235	Washer	EN 1.4301(AISI 304)
025	Plug	EN 1.4404 (AISI 316L)	244	Plug [1]	EN 1.4301(AISI 304)
026	O-Ring	FKM			

[1]= Not for H and E versions

3 - 3L SERIES

CENTRIFUGAL ELECTRIC PUMPS STANDARDISED IN COMPLIANCE WITH EN 733 (EX DIN 24255)

MECHANICAL SEAL standard version

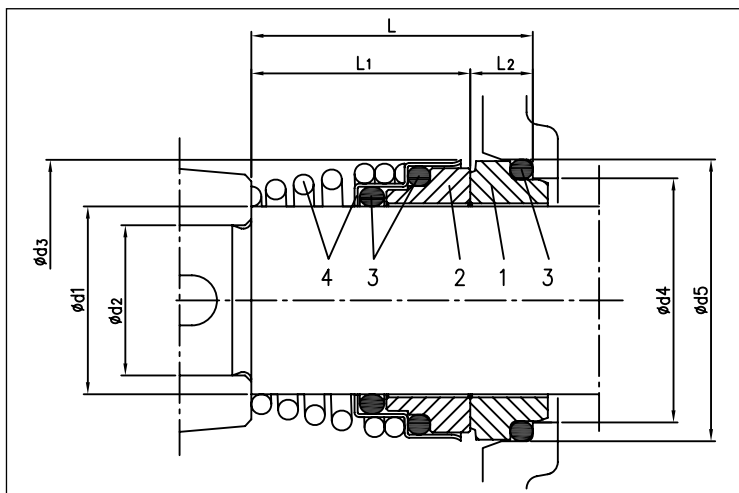

MATERIALS TABLE

Ref.	Name	Materials	
		3 SERIES	3L SERIES
1	Fixed part	Carbon	Silicon Carbide
2	Rotating part	Ceramic	Silicon Carbide
3	Gasket	NBR	FKM
4	Frame + spring	EN 1.4401 (AISI 316)	EN 1.4571 (AISI 316Ti)

SPECIAL MECHANICAL SEALS 3 SERIES (On request)

Name	Materials				
	H Version	HS Version	HW Version	HSW Version	E Version
Fixed part	Carbon	Silicon Carbide	Tungsten Carbide	Tungsten Carbide	Carbon
Rotating Part	Ceramic	Silicon Carbide	Tungsten Carbide	Silicon Carbide	Ceramic
Elastomers	FKM	FKM	FKM	FKM	EPDM
Spring	AISI 316	AISI 316Ti	AISI 316	AISI 316	AISI 316Ti
Structure/Frame	AISI 316	AISI 316Ti	AISI 316	AISI 316	AISI 316Ti

SPECIAL MECHANICAL SEALS 3L SERIES (On request)

Name	Materials				
	H Version	HW Version	HSW Version	E* Version	ES** Version
Fixed part	Carbon	Tungsten Carbide	Tungsten Carbide	Carbon	Carbon
Rotating Part	Ceramic	Tungsten Carbide	Silicon Carbide	Ceramic	Silicon Carbide
Elastomers	FKM	FKM	FKM	EPDM	EPDM
Spring	AISI 316	AISI 316	AISI 316	AISI 316Ti	AISI 316Ti
Structure/Frame	AISI 316	AISI 316	AISI 316	AISI 316Ti	AISI 316Ti

* Not available for 3 I 80-250 SERIES 2 poles
 ** Available only for 3 I 80-250 SERIES 2 poles

SPECIAL MECHANICAL SEALS 3-3L SERIES (On request)

Name	Materials				
	U3U3EGG Version	U3CEGG Version	Q1Q1EGG Version	Q1U3EGG Version	Q1AEGG Version
Fixed part	Tungsten Carbide	Tungsten Carbide	Silicon Carbide	Silicon Carbide	Silicon Carbide
Rotating Part	Tungsten Carbide	Special carbon	Silicon Carbide	Tungsten Carbide	Metallised carbon
Elastomers	EPDM	EPDM	EPDM	EPDM	EPDM
Spring	AISI 316	AISI 316	AISI 316	AISI 316	AISI 316
Structure/Frame	AISI 316	AISI 316	AISI 316	AISI 316	AISI 316

3 - 3L SERIES

**CENTRIFUGAL ELECTRIC PUMPS STANDARDISED IN COMPLIANCE WITH EN 733
(EX DIN 24255)**

ELECTRIC DATA TABLE 3(L)M SERIES

2 Poles

Model		P ₂		Efficiency		Capacitor		Efficiency(%)			P ₁		Absorbed Current [A]			
Single phase	Three phase	[HP]	[kW]	Single phase	Three phase	Single phase µF	V _c	Three phase			Single phase	Three phase	Three phase			
								50%	75%	100%	[kW]	[kW]	230V	230V	400V	690V
3(L)M 32-125/1.1 M	3(L)M(Z) 32-125/1.1	1,5	1,1	-	IE3	31,5	450	83,0	85,8	85,6	1,51	1,77	6,7	5,8	3,3	-
3(L)M 32-160/1.5 M	3(L)M(Z) 32-160/1.5	2	1,5	-	IE3	40	450	83,0	85,8	85,6	2,10	1,77	9,6	5,8	3,3	-
3(L)M 32-160/2.2 M	3(L)M(Z) 32-160/2.2	3	2,2	-	IE3	50	450	86,2	87,0	86,0	2,95	2,55	13,3	8,2	4,7	-
-	3(L)M(Z) 32-200/3.0	4	3	-	IE3	-	-	85,9	87,5	87,1	-	3,44	-	11,1	6,4	-
-	3(L)M(Z) 32-200/4.0	5,5	4	-	IE3	-	-	85,8	88,3	88,4	-	4,52	-	15,1	8,7	-
-	3(L)M(Z) 32-200/5.5	7,5	5,5	-	IE3	-	-	89,2	90,6	90,4	-	6,09	-	-	10,6	6,1
-	3(L)M(Z) 32-200/7.5	10	7,5	-	IE3	-	-	89,0	90,7	90,8	-	8,26	-	-	13,6	7,9
3(L)M 40-125/1.5 M	3(L)M(Z) 40-125/1.5	2	1,5	-	IE3	40	450	83,0	85,8	85,6	2,10	1,77	9,6	5,8	3,3	-
3(L)M 40-125/2.2 M	3(L)M(Z) 40-125/2.2	3	2,2	-	IE3	50	450	86,2	87,0	86,0	2,95	2,55	13,3	8,2	4,7	-
-	3(L)M(Z) 40-160/3.0	4	3	-	IE3	-	-	85,9	87,5	87,1	-	3,44	-	11,1	6,4	-
-	3(L)M(Z) 40-160/4.0	5,5	4	-	IE3	-	-	85,8	88,3	88,4	-	4,52	-	15,1	8,7	-
-	3(L)M(Z) 40-200/5.5	7,5	5,5	-	IE3	-	-	89,2	90,6	90,4	-	6,09	-	-	10,6	6,1
-	3(L)M(Z) 40-200/7.5	10	7,5	-	IE3	-	-	89,0	90,7	90,8	-	8,26	-	-	13,6	7,9
-	3(L)M(Z) 40-200/11	15	11	-	IE3	-	-	90,4	91,2	91,8	-	11,98	-	-	21,3	12,3
3(L)M 50-125/2.2 M	3(L)M(Z) 50-125/2.2	3	2,2	-	IE3	50	450	86,2	87,0	86,0	2,95	2,55	13,3	8,2	4,7	-
-	3(L)M(Z) 50-125/3.0	4	3	-	IE3	-	-	85,9	87,5	87,1	-	3,44	-	11,1	6,4	-
-	3(L)M(Z) 50-125/4.0	5,5	4	-	IE3	-	-	85,8	88,3	88,4	-	4,52	-	15,1	8,7	-
-	3(L)M(Z) 50-160/5.5	7,5	5,5	-	IE3	-	-	89,2	90,6	90,4	-	6,09	-	-	10,6	6,1
-	3(L)M(Z) 50-160/7.5	10	7,5	-	IE3	-	-	89,0	90,7	90,8	-	8,26	-	-	13,6	7,9
-	3(L)M(Z) 50-200/9.2	12,5	9,2	-	IE3	-	-	90,1	90,8	90,9	-	10,12	-	-	17,2	10,0
-	3(L)M(Z) 50-200/11	15	11	-	IE3	-	-	90,4	91,2	91,8	-	11,98	-	-	21,3	12,3
-	3(L)M(Z) 50-200/15	20	15	-	IE3	-	-	91,2	92,0	91,9	-	18,00	-	-	30,0	17,3
-	3(L)M(Z) 65-125/4	5,5	4	-	IE3	-	-	85,8	88,3	88,4	-	4,52	-	15,1	8,7	-
-	3(L)M(Z) 65-125/5.5	7,5	5,5	-	IE3	-	-	89,2	90,6	90,4	-	6,09	-	-	10,6	6,1
-	3(L)M(Z) 65-125/7.5	10	7,5	-	IE3	-	-	89,0	90,7	90,8	-	8,26	-	-	13,6	7,9
-	3(L)M(Z) 65-160/7.5	10	7,5	-	IE3	-	-	89,0	90,7	90,8	-	8,26	-	-	13,6	7,9
-	3(L)M(Z) 65-160/9.2	12,5	9,2	-	IE3	-	-	90,1	90,8	90,9	-	10,12	-	-	17,2	10,0
-	3(L)M(Z) 65-160/11	15	11	-	IE3	-	-	90,4	91,2	91,8	-	11,98	-	-	21,3	12,3
-	3(L)M(Z) 65-160/15	20	15	-	IE3	-	-	91,2	92,0	91,9	-	16,32	-	-	27,7	17,3
-	3(L)M(Z) 65-200/15	20	15	-	IE3	-	-	91,2	92,0	91,9	-	16,32	-	-	27,7	17,3
-	3(L)M(Z) 65-200/18.5	25	18,5	-	IE3	-	-	91,6	93,0	92,6	-	19,98	-	-	35,0	20,3
-	3(L)M(Z) 65-200/22	30	22	-	IE3	-	-	92,0	93,1	93,2	-	23,58	-	-	39,7	23,6
-	3LM 80-160/11	15	11	-	IE3	-	-	90,4	91,2	91,8	-	11,98	-	-	21,3	12,3
-	3LM 80-160/15R	20	15	-	IE3	-	-	91,2	92,0	91,9	-	16,32	-	-	27,7	17,3
-	3LM 80-160/15	20	15	-	IE3	-	-	91,2	92,0	91,9	-	16,32	-	-	27,7	17,3
-	3LM 80-160/18.5	25	18,5	-	IE3	-	-	91,6	93,0	92,6	-	19,98	-	-	35,0	20,3